

No Powder White Ink DTF Printing Solution

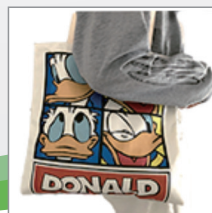

HJ-603

Newly upgraded



Process Features:

- **Digital customization:** digital transferring process, no plate, no engraving, short process, personalized, immediately available.
- **Environmental friendly:** water-based environmentally friendly DTF ink, bright color and non-fading, pollution-free production process, guaranteed product safety.
- **Features:** unique CO ink, design, printing, transferring at one time, no powder, saving process and material costs.
- **Return to the original:** suitable for various fabrics, leathers, coil plates, does not affect the texture and feel of the original material.
- **Color fastness:** high textile printing color fastness, high resistance to scratching and bending, good air permeability, high weather resistance, hydrolysis resistance.
- **Reasonable structure:** the printer and dryer are light in design and compact in structure, saving floor space.
- **Intelligent drying:** intelligent temperature-controlled hot air circulation system, effective use of heat circulation, save power consumption.
- **Intelligent purification:** standard patent smoke exhaust system, effectively remove internal moisture, ensure drying effect, small size, low noise.

Process Flow:

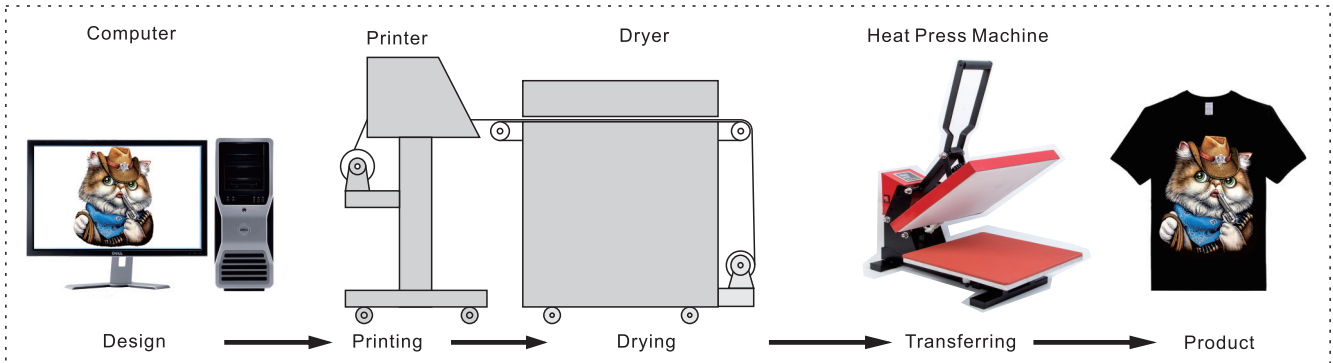

Printing Principle:

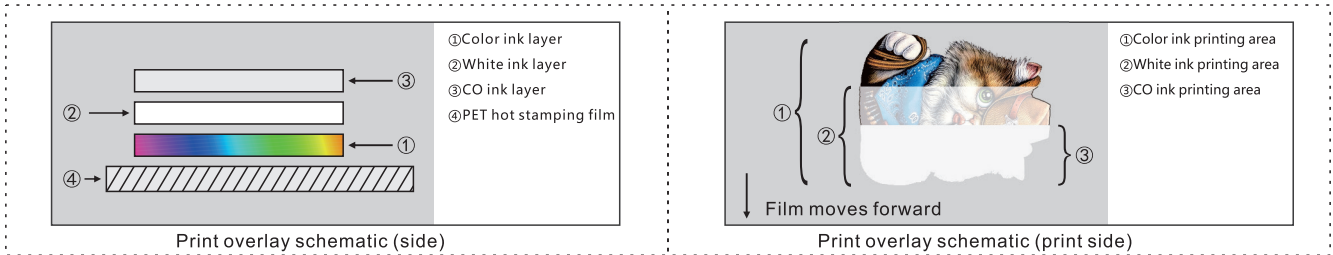

Parameter specifications:

Printer				Dryer			
Model	HJ-603			Model	HJ-H602		
Print head	Epson i3200-A1			Drying mode	Intelligent temperature controlled hot air circulation drying system + front guide plate drying system		
Printhead No.	3-4						
Ink type	Water-based eco-friendly dtf ink			Temperature range	150°C		
Color	KCMY+W+CO			Drying tunnel Length and Width	W:700mm, L:1150mm		
Printing capacity	Economy mode	4pass	12m ² /h	Drying tunnel Height	25mm		
	Production mode	6pass	8m ² /h	Loading system	Dual power motor adjustable damping paper stacker		
	Quality mode	8pass	6m ² /h				
Printing format	600mm			Power	AC220V 50/60Hz	maximum power	8.0KW
Printing media	PET film				16A	working power	4.9KW
Ink supplying	Big capacity continuous ink supplying system, low liquid level alarm			Equipment dimension and weight			
	White ink system	Intelligent automatic circulation mixing system			Working area	W×L	3000*3500mm
Print head protection	Intelligent dual side high sensitivity anti scratch system			Printer	W×L×H	1980*1090*1450mm	
Printing height	Manual knob adjustable				Weight	223KG	
RIP software	RIIN,MainTop,PhotoPrint			Dryer	W×L×H	1640*1140*1120mm	
Printing software	HOSON_PrintExp				Weight	236KG	
Operating system	CPU:i5/i7 RAM:8GB HDD:500GB Win7/10 64bit			Equipment dimension and weight			
Interface	kMbps network			Printer	W×L×H	2160*1150*870mm	
Power	AC220V 50/60Hz 10A,maximum power: 1.2kW				Weight	320KG	
Working environment	temperature:20°C-26°C humidity:35%-65%			Dryer	W×L×H	1750*1250*1340mm	
					Weight	330KG	